

STATIC PULVERISER

OKP2000

Item		Spec.
Operating Weight	kg	1,800
	lb	3,970
Overall Length	mm	1,836
	Inch	72.28
Overall Width	mm	1,430
	Inch	56.29
Arm Width	mm	320
	Inch	12.59
Max. Opening Width	mm	850
	Inch	33.46
Cutter Length	mm	200
	Inch	7.84
Crushing Force	ton (A)	120
	ton (B)	150
	ton (C)	178
	ton (D)	220
Cutting Force	ton	270
Operating Pressure	kg/cm ²	300
	psi	4,267
Oil Flow Rate	LPM	250 ~ 300
	GPM	66.1 ~ 79.2
Speed-Up Valve		Option
Suitable Excavator	ton	18 ~ 26

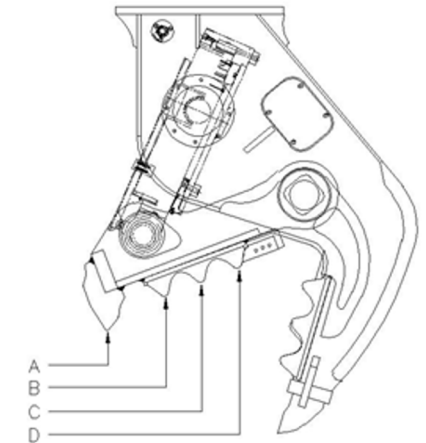
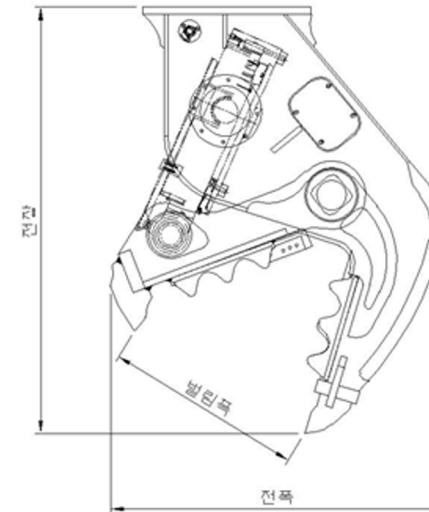

Arm Speed		
Opening / Closing Normal Time	Opening (sec)	1.53
	Closing (sec)	3.50
	Total Cycle (sec)	5.02
Opening / Closing Speed-Up Time	Opening (sec)	1.53
	Closing (sec)	1.97
	Total Cycle (sec)	3.50
(Based Oil Flow)	LPM	220

* This will follow in equipment efficiency and there is a possibility which there will be a difference